

|  |   |  |   |
|--|---|--|---|
|  <b>KTR</b> Kupplungstechnik<br>GmbH<br>D-48407 Rheine | <b>CLAMPEX® KTR 603</b><br><b>mounting instructions</b> |  | KTR-N 40821 E<br>sheet: 1<br>edition: 2 |
|  |   |  |   |
|  |   |  |   |

The **CLAMPEX®** clamping set is a frictionally engaged, detachable shaft - hub connection for cylindrical shafts and bores without feather key.

### General Hints

Please read through these mounting instructions carefully before assembling the clamping set.

Please pay special attention to the safety instructions!

The mounting instructions are part of your product. Please keep them carefully and close to the clamping set.

The copyright for these mounting instructions remains with **KTR** Kupplungstechnik GmbH.

### Safety and Advice Hints



**DANGER!**

**Danger of injury to persons.**



**CAUTION!**

**Damages on the machine possible.**



**ATTENTION!**

**Pointing to important items.**

### General Hints to Danger



**DANGER!**

**With assembly and disassembly of the clamping set it has to be made sure that the entire drive train is protected against unintentional engagement. You can be seriously hurt by rotating parts. Please make absolutely sure to read through and observe the following safety instructions.**

- All operations on and with the clamping set have to be performed taking into account "safety first".
- Please make sure to disengage the power pack before you perform your work at the clamping set.
- Protect the power pack against unintentional engagement, e. g. by providing hints at the place of engagement or removing the fuse for current supply.
- Do not touch the operation area of the machine as long as it is in operation.
- Please protect the rotating drive parts against unintentional touch. Please provide for the necessary protection devices and caps.

### Proper Use

You may only assemble and disassemble the clamping set if you

- carefully read through the mounting instructions and understood them
- had technical training
- are authorized to do so by your company

The clamping set may only be used in accordance with the technical data (see **CLAMPEX®** catalogue). Unauthorized modifications on the clamping set are not admissible. We do not take any warranty for resulting damages. To further develop the product we reserve the right for technical modifications. The **CLAMPEX®** clamping set described in here corresponds to the technical status at the time of printing of these mounting instructions.

|                                      |                             |                                |
|--------------------------------------|-----------------------------|--------------------------------|
| Schutzvermerk<br>ISO 16016 beachten. | Gezeichnet: 20.09.06 Sha/Hg | Ersatz für: KTR-N vom 10.07.01 |
|                                      | Geprüft: 20.09.06 Sha       | Ersetzt durch:                 |



The clamping set is generally delivered in assembled condition.

**Tolerances, surfaces**

A good rotating process is sufficient:  
**Rz ≤ 16µm**

Highest permissible tolerance:  
**d = h8 for the hub** (hollow shaft outside)

**Components of CLAMPEX® KTR 603**

| component | quantity      | designation                              |
|-----------|---------------|--|
| 1         | 1             | front external ring (with through holes) |
| 2         | 1             | back external ring (with tappings)       |
| 3         | 1             | internal ring (slotted)                  |
| 4         | see catalogue | hexagonal screws DIN 933                 |

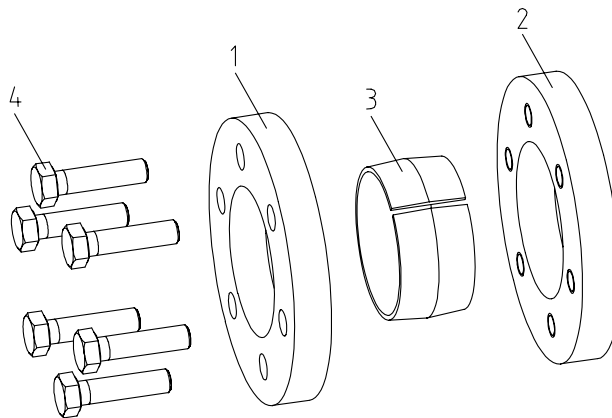

picture 1: CLAMPEX® KTR 603



**ATTENTION!**

Dirty or used clamping sets must be disassembled before the installation in order to be cleaned. Afterwards only the taper surfaces and the clamping screws must be greased with Molykote MoS<sub>2</sub> (see picture 2).

**Assembly**

- Check the shaft and hub position regarding the permitted tolerance (see table 1).
- The contact surfaces of shaft / hollow shaft inside and shaft must be cleaned and degreased.

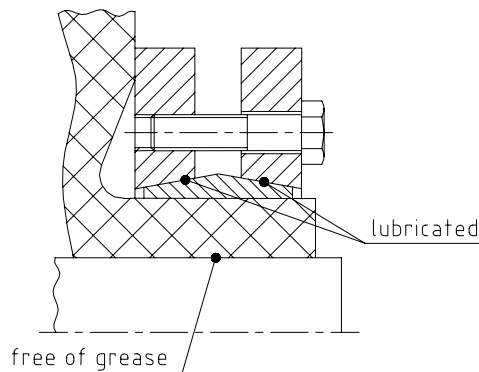

picture 2



**CAUTION!**

Contact surfaces of shaft and hub bore (hollow shaft inside) must neither be greased nor be oiled (see picture 2).

|                                      |                             |                                |
|--------------------------------------|-----------------------------|--------------------------------|
| Schutzvermerk<br>ISO 16016 beachten. | Gezeichnet: 20.09.06 Sha/Hg | Ersatz für: KTR-N vom 10.07.01 |
|                                      | Geprüft: 20.09.06 Sha       | Ersetzt durch:                 |



## Assembly

### Continuation:

- Loosen the clamping screws slightly and put the clamping set KTR 603 externally onto the hub / hollow shaft.



#### ATTENTION!

In the area of the position of the external clamping set the external surface of the hub (outside hollow shaft) can be greased.



#### CAUTION!

Before tightening the clamping screws install the shaft.

- Slightly tighten the clamping screws manually and align the external clamping set with hub part / hollow shaft.
- Inspect the external rings of the external clamping set for plane-parallel characteristics.
- Tighten the clamping screws evenly and successively. Increase the tightening torque step by step. This must be repeated until reaching the tightening torque indicated in table 2 at all clamping screws.

**Table 1:**

|                             |          |          |          |           |
|-----------------------------|----------|----------|----------|-----------|
| shaft-Ø d <sub>w</sub> [mm] | 18 to 30 | 31 to 50 | 51 to 80 | 81 to 500 |
| tolerance                   | H6 / j6  | H6 / h6  | H6 / g6  | H7 / g6   |

**Table 2:**

|                                       |         |    |    |     |     |     |     |
|---------------------------------------|---------|----|----|-----|-----|-----|-----|
| type of clamping set                  | KTR 603 |    |    |     |     |     |     |
| screw size M                          | M5      | M6 | M8 | M10 | M12 | M16 | M20 |
| tightening torque T <sub>A</sub> [Nm] | 4       | 12 | 30 | 59  | 100 | 250 | 490 |

## Disassembly



#### DANGER!

Loosened or falling drive parts can cause injuries to persons or damages to the machines. Safe the drive parts before the disassembly.

- Detach all clamping screws evenly and successively. Do not unscrew the clamping screws completely from the thread.



#### CAUTION!

To reduce the tension forces the clamping screws must not be unscrewed completely.

- The clamping sets are not self-locking. If the front and the back external taper ring don't loose, the loosening process must be started by a slight pressure onto the front and the back external taper ring on the circumference.
- Remove shaft from the hub / hollow shaft.
- Draw the clamping set KTR 603 off the hub / hollow shaft.



#### CAUTION!

In case of non-observance of these hints or in case of non-considerance of the operating conditions regarding the selection of the clamping set, the function of the clamping set can be influenced.

### Disposal of waste:

**Defective clamping sets must be cleaned and scrapped.**

|                                      |                             |                                |
|--------------------------------------|-----------------------------|--------------------------------|
| Schutzvermerk<br>ISO 16016 beachten. | Gezeichnet: 20.09.06 Sha/Hg | Ersatz für: KTR-N vom 10.07.01 |
|                                      | Geprüft: 20.09.06 Sha       | Ersetzt durch:                 |